

# DJW SERIES

## DJW6-7.0 (6V7.0Ah)

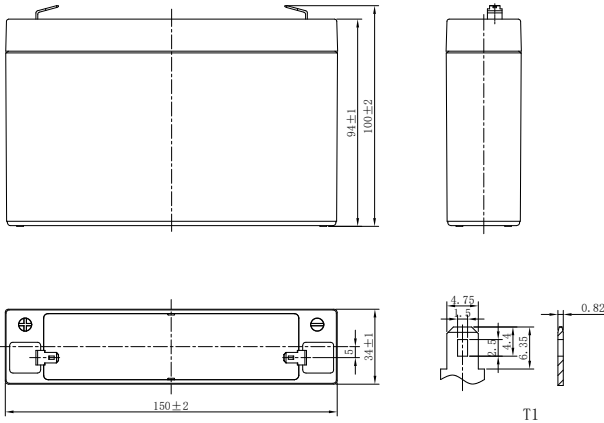

### CHARACTERISTICS

Item	Specifications	
Rated Voltage	6V	
Nominal Capacity (25°C)	C <sub>20</sub> : 1.75V/cell	7.0Ah
Dimension	Length	150mm (5.91inches)
	Width	34mm (1.34inches)
	Container Height	94mm (3.70inches)
	Total Height	100mm (3.94inches)
Approx Weight	1.00kg (2.20lbs)	
Terminal	T1/T2	
Container Material	ABS (UL94 HB or V-0 optional)	
Short-circuit current	196A	
Internal Resistance (25°C)	Approx 17 mΩ (Fully charged)	
Operating Temp. Range	Discharge	-15~50°C (5~122°F)
	Charge	-20~40°C (-4~104°F)
	Storage	-15~40°C (5~104°F)
Nominal Operating Temp. Range	25±3°C (77±5°F)	
Max. Charging Current (25°C)	0.3C	
Charge voltage (25°C)	Standby Use	Cycle Use
	2.25-2.30V/cell	2.35-2.45V/cell
Temp. Coefficient	-3mV/cell/°C	
	-5mV/cell/°C	
Effect of temp. to Capacity	40°C (104°F)	103%
	25°C (77°F)	100%
	0°C (32°F)	86%
Self Discharge	≤3% per month at 25°C (77°F). DJW series batteries may be stored up to 6 months at 25°C (77°F) and then a freshening charge is required. For higher temperatures the time interval will be shorter.	

### DISCHARGE TABLE

Constant Current Discharge (Amperes) at 25°C (77°F)																
F.V/Time	5min	10min	15min	20min	30min	45min	1h	1.5h	2h	3h	4h	5h	6h	8h	10h	20h
1.85V/cell	17.0	12.5	9.90	8.10	6.12	4.64	3.91	2.90	2.38	1.72	1.36	1.16	0.990	0.780	0.637	0.343
1.80V/cell	18.5	13.2	10.3	8.35	6.28	4.73	3.99	2.95	2.41	1.74	1.38	1.18	1.01	0.790	0.644	0.347
1.75V/cell	19.9	13.8	10.7	8.60	6.43	4.83	4.06	3.00	2.45	1.77	1.40	1.19	1.02	0.800	0.653	0.350
1.70V/cell	21.4	14.4	11.1	8.86	6.57	4.92	4.13	3.05	2.49	1.79	1.42	1.21	1.03	0.809	0.660	0.354
1.67V/cell	22.3	14.8	11.3	9.01	6.67	4.98	4.17	3.08	2.51	1.81	1.43	1.22	1.04	0.816	0.665	0.356
1.60V/cell	24.3	15.7	11.8	9.40	6.87	5.11	4.27	3.14	2.56	1.84	1.46	1.24	1.06	0.829	0.675	0.361
Constant Power Discharge (Watts/cell) at 25°C (77°F)																
F.V/Time	5min	10min	15min	20min	30min	45min	1h	1.5h	2h	3h	4h	5h	6h	8h	10h	20h
1.85V/cell	32.3	23.9	19.1	15.6	11.8	9.01	7.61	5.67	4.65	3.37	2.69	2.29	1.96	1.55	1.27	0.686
1.80V/cell	34.8	25.0	19.7	16.0	12.1	9.15	7.73	5.74	4.71	3.42	2.72	2.32	1.99	1.57	1.28	0.693
1.75V/cell	37.4	26.1	20.3	16.4	12.3	9.30	7.84	5.82	4.77	3.46	2.76	2.35	2.01	1.58	1.29	0.700
1.70V/cell	39.9	27.2	20.9	16.8	12.5	9.40	7.95	5.90	4.84	3.50	2.79	2.37	2.03	1.60	1.31	0.707
1.67V/cell	41.4	27.8	21.3	17.1	12.7	9.50	8.02	5.95	4.87	3.53	2.81	2.39	2.05	1.61	1.32	0.712
1.60V/cell	44.7	29.2	22.1	17.6	13.0	9.70	8.17	6.05	4.95	3.59	2.85	2.43	2.08	1.64	1.34	0.722

# DJW SERIES

## DJW6-7.0 (6V7.0Ah)



### APPLICATIONS

- Uninterruptable Power Supply (UPS)
- Electric Power System (EPS)
- Emergency backup power supply
- Alarm and security system
- Communication power supply
- DC power supply
- Auto control system

### GENERAL FEATURES

- 5 years design life (25°C)
- Lead calcium alloy, sealed design, no watering required
- Puncture resistant micro-porous glass mat separators extend life
- Unique technology optimizes power capacity, cell consistency, and long-term reliability
- Designed for a wide range of applications

### STANDARDS

- Compliance with IEC 60896 standards, EU Battery Directive
- UL, CE Approved
- Manufactured in Leoch@IATF 16949, ISO 45001, ISO 9001 and ISO 14001 certified production facilities

#### Discharge Characteristics

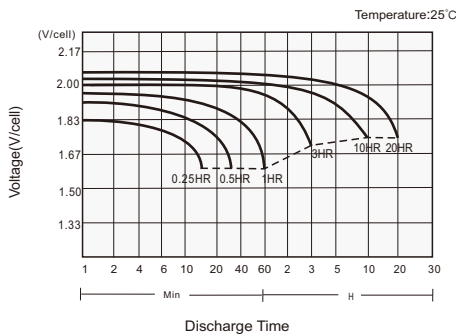

#### Charging Characteristics

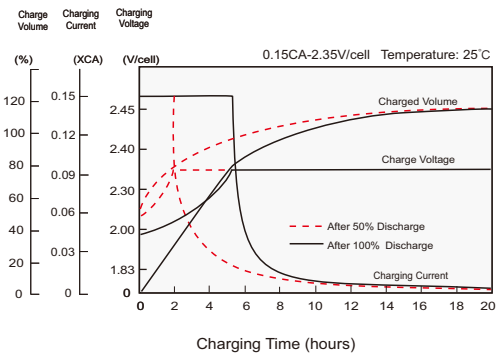

#### Effects of Temperature on Capacity

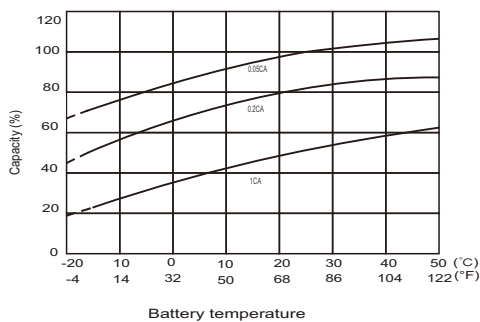

#### Self Discharge Characteristics

