

DJM SERIES

DJM12200 (12V200Ah)

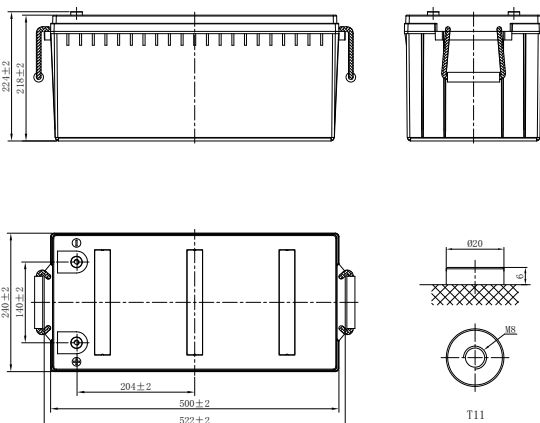

CHARACTERISTICS

Item	Specifications	
Rated Voltage	12V	
Nominal Capacity (25°C)	C ₁₀ : 1.80V/cell	200Ah
Dimension	Length	522mm (20.6inches)
	Width	240mm (9.45inches)
	Container Height	218mm (8.58inches)
	Total Height	224mm (8.82inches)
Approx Weight	62.3kg (137.3lbs)	
Terminal	T11(M8)	
Container Material	ABS (UL94 HB or V-0 optional)	
Short-circuit current	3600A	
Internal Resistance (25°C)	Approx 3.2 mΩ (Fully charged)	
Operating Temp. Range	Discharge	-15~50°C (5~122°F)
	Charge	-20~40°C (-4~104°F)
	Storage	-15~40°C (5~104°F)
Nominal Operating Temp. Range	25±3°C (77±5°F)	
Max.Charging Current (25°C)	0.3C	
Charge voltage (25°C)	Standby Use	Cycle Use
	2.25-2.30V/cell	2.35-2.40V/cell
Temp. Coefficient	-3mV/cell/°C	-5mV/cell/°C
	40°C (104°F)	103%
Effect of temp. to Capacity	25°C (77°F)	100%
	0°C (32°F)	86%
	≤3% per month at 25°C (77°F). DJM series batteries may be stored up to 6 months at 25°C (77°F) and then a freshening charge is required. For higher temperatures the time interval will be shorter.	
Self Discharge		

DISCHARGE TABLE

Constant Current Discharge (Amperes) at 25°C (77°F)														
F.V/Time	10min	15min	20min	30min	45min	1h	2h	3h	4h	5h	6h	8h	10h	20h
1.85V/cell	281.1	243.7	200.7	157.7	117.8	101.8	63.3	46.4	36.4	31.6	27.9	21.4	19.1	10.1
1.80V/cell	319.1	276.2	224.0	171.7	124.8	105.5	65.4	50.4	38.9	33.3	29.9	22.6	20.0	10.5
1.75V/cell	346.0	299.0	237.1	175.2	129.3	110.7	68.8	51.4	39.6	33.9	30.2	22.7	20.2	10.6
1.70V/cell	368.9	317.6	248.2	178.7	131.9	112.9	70.2	52.4	40.3	34.4	30.3	23.0	20.4	10.7
1.67V/cell	380.6	326.8	254.1	181.3	133.8	114.6	71.2	52.9	40.9	35.1	30.5	23.3	20.7	10.8
1.60V/cell	393.6	337.0	260.5	183.9	135.7	116.2	72.3	53.4	41.4	35.6	30.7	23.6	20.9	11.0

Constant Power Discharge (Watts/cell) at 25°C (77°F)														
F.V/Time	10min	15min	20min	30min	45min	1h	2h	3h	4h	5h	6h	8h	10h	20h
1.85V/cell	528.8	461.4	381.4	301.3	226.4	197.0	123.2	90.8	71.5	62.3	55.1	42.5	38.0	20.2
1.80V/cell	591.5	516.2	420.9	325.5	238.3	202.9	126.6	98.0	76.0	65.2	58.9	44.6	39.7	20.9
1.75V/cell	631.3	550.9	440.3	329.6	245.5	212.0	132.7	99.7	77.2	66.2	59.2	44.7	40.1	21.1
1.70V/cell	663.7	579.1	456.3	333.4	248.6	215.1	134.8	101.2	78.2	67.1	59.4	45.4	40.4	21.3
1.67V/cell	674.5	588.6	462.2	335.7	250.9	217.0	136.2	101.8	79.2	68.2	59.5	45.9	40.9	21.5
1.60V/cell	683.9	596.8	467.0	337.2	252.1	218.6	137.3	102.2	79.7	68.9	59.8	46.4	41.3	21.7

DJM SERIES

DJM12200 (12V200Ah)



APPLICATIONS

- UPS and EPS
- Emergency light
- Railway signal and aircraft signal system
- Marine and power stations
- Alarm and security system
- Electronic apparatus and equipment
- Communication power supply, DC power supply

GENERAL FEATURES

- 12 years design life (25°C)
- Lead calcium alloy, sealed design, no watering required
- Puncture resistant micro-porous glass mat separators extend life
- Unique technology optimizes power capacity, cell consistency, and long-term reliability
- Designed for a wide range of applications

STANDARDS

- Compliance with IEC 60896 standards, EU Battery Directive
- UL, CE Approved
- Manufactured in Leoch@IATF 16949, ISO 45001, ISO 9001 and ISO 14001 certified production facilities

Discharge Characteristics

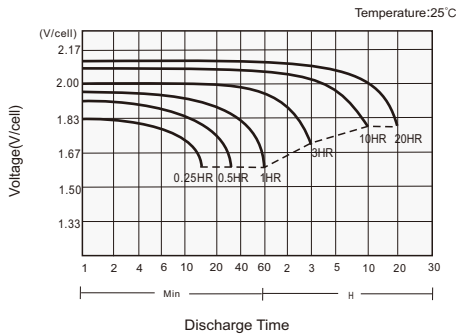

Charging Characteristics

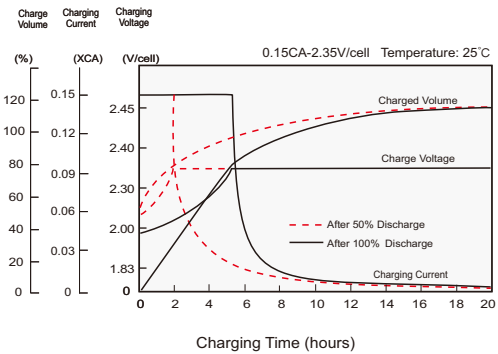

Effects of Temperature on Capacity

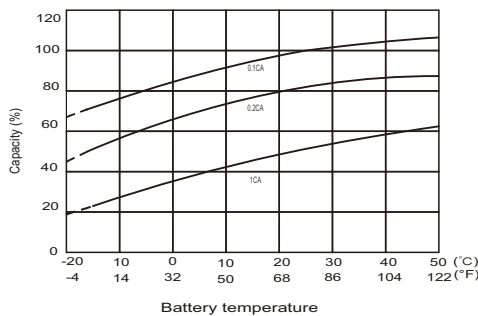

Self Discharge Characteristics

